

IMPORTANT - READ OPERATOR'S MANUAL BEFORE OPERATING OR MAKING ADJUSTMENTS.

Seat Adjustment

Loosen bolts on sliding brackets under each side of the seat, slide seat forward or rearward to desired position. Tighten bolts. Do not operate the mower with bracket bolts in "loose" condition.

Mower Blade Operation

To engage the mower blades, turn lever on floor, slowly, to the "ON" position. To disengage mower blades, turn lever, slowly, to the "OFF" position.

Removing The Body

1. Disconnect Throttle cable from engine.
2. Disconnect the wiring loom from the body by turning the threaded collar on the connector in a counterclockwise direction. This connector is located at the left rear of the body.
3. Remove four control lever bolts, and remove upper control levers, (P/N 9079 & 9080).
4. Remove the two attach nuts on the floor of the body and release the latches on the rear of the body, near each side.
5. Place height adjustment lever in the vertical position, and mower deck engaging lever in the "OFF" position. Carefully lift the body off the chassis.
6. For assembly, reverse the procedure.

Removing The Mower Deck

1. Loosen the belt keeper, (P/N 2294), located under the engine by loosening two rear engine mounting bolts, allowing the deck drive belt to come free of the rear pulley. Tighten the belt keeper.
2. Disconnect the wiring loom at the deck safety switch, (P/N 4242).
3. Remove four attach pins, (P/N 6107) and clips, (P/H 3072) from the deck attach points and stabilizer bars.
4. Lift the front of the mower chassis clear of the deck engaging rod, (P/N 2686). Roll the chassis free of the deck.
5. To install, reverse the procedure.

Adjustment Of Mower Deck Drive Belt

1. Disengage the mower deck drive belt.
2. To obtain the proper belt tension, loosen lock nut, (P/N 3005) and rotate engaging rod linkage, (P/N 3607).
3. After making an adjustment, engage the drive belt and check the tension. (The proper tension for an engaged V-belt is the lowest tension at which the belt will not slip under normal load conditions.)
4. If further adjustment is necessary, repeat steps 1 through 3, until proper adjustment is achieved.
5. After the belt tension is adjusted, check to assure that the mower blade will not turn freely when the engaging rod is in the "OFF" position.
6. If the mower blade turns freely, adjust the blade brake using swivel fitting, (P/N 2172), located on the brake linkage "L" rod, (P/N 2841) so that there is 1/8" to 1/4" gap between the deck safety switch body, (P/N 4242), and the striker plate, attached to the clutch idler bracket, (P/N 2847), when the brake is engaged.

NOTE: The clutch idler bracket, (P/N 2847) must be raised so that the brake link swivel, (P/N 2172) can be adjusted.

7. After adjustment is achieved, perform the safety checks listed below.

"IMPORTANT" - Perform SAFETY CHECKS after making any repairs or adjustments.

1. After reassembly, while seated on the mower, attempt to start the engine with the mower deck engaged. Engine should not start. If engine does start, return the mower to an Authorized Dixon Dealer for adjustment or repair.
2. Disengage the mower deck and start engine. With the operator in the normal seated position, engage mower deck and remove weight from the seat. The engine should stop. If the engine doesn't stop when operator rises from the seat, return the mower to an Authorized Dixon Dealer for adjustment or repair.
3. Engage, then disengage, mower blade in each cutting height. Insure that blade disengages and comes to a stop within 5 seconds in each height position. If blade does not disengage properly, repeat belt adjustment procedure or contact your Authorized Dixon Dealer.

Removing The Mower Blade

Secure the blade, (P/N 6013) from turning. (Observe the blade position when removing.) Remove the blade bolt from the center of the blade, remove the blade flange, (P/N 2837), blade, (P/N 2406), and spacer, (P/N 2829).

WARNING: Sharp edges on the blade can cause injury! Caution should be exercised when service is required on the blade.

Parking Brake Adjustment

Remove the body as described above. Tighten nut on brake rod, (P/N 2533), (Located in front of the transaxle on each side), just enough to prevent brake from slipping when engaged.

CAUTION: Over-tightening may cause premature wear on the brake band, (P/N 5085).



CHASSIS ASSEMBLY (MODEL 308 & 311)

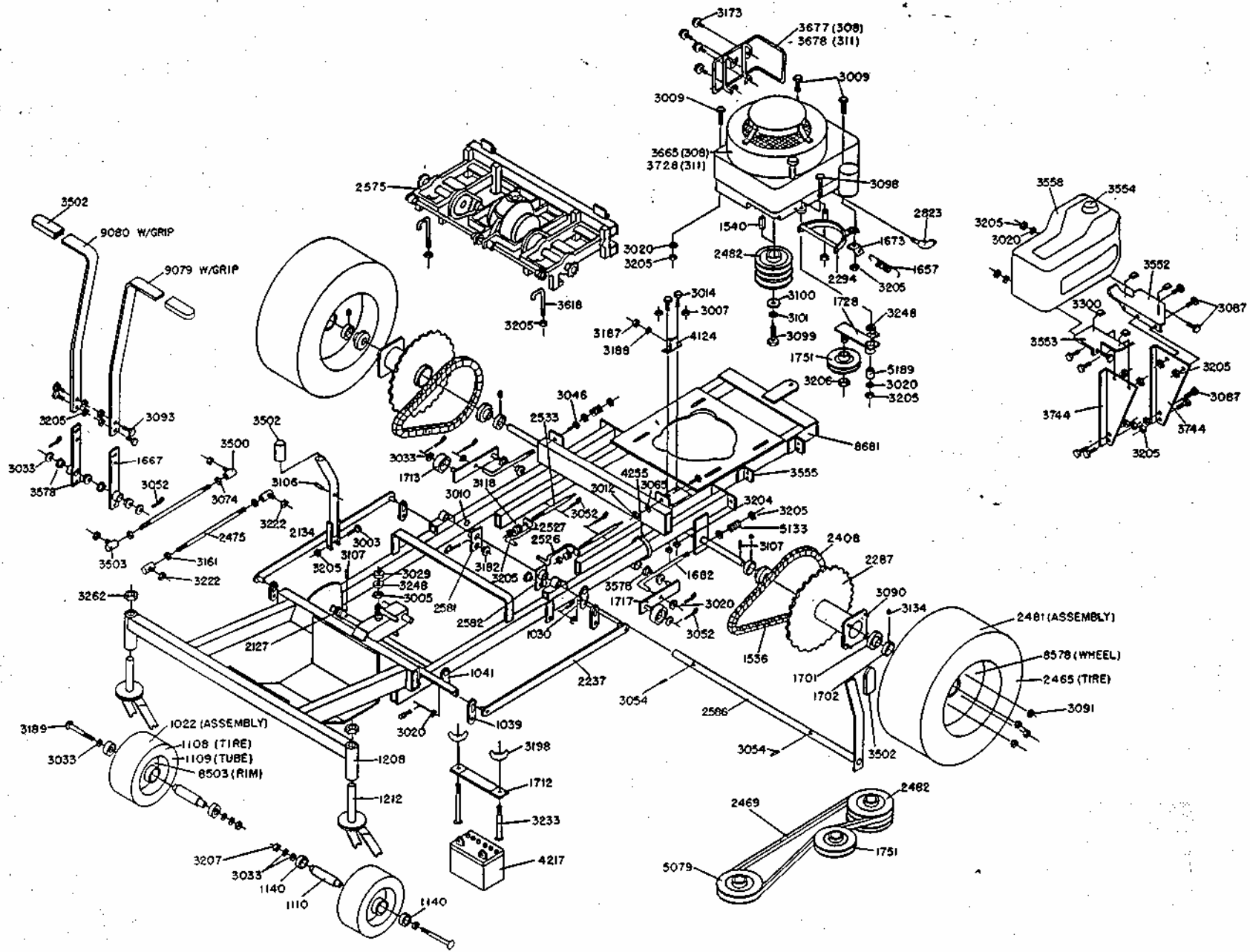

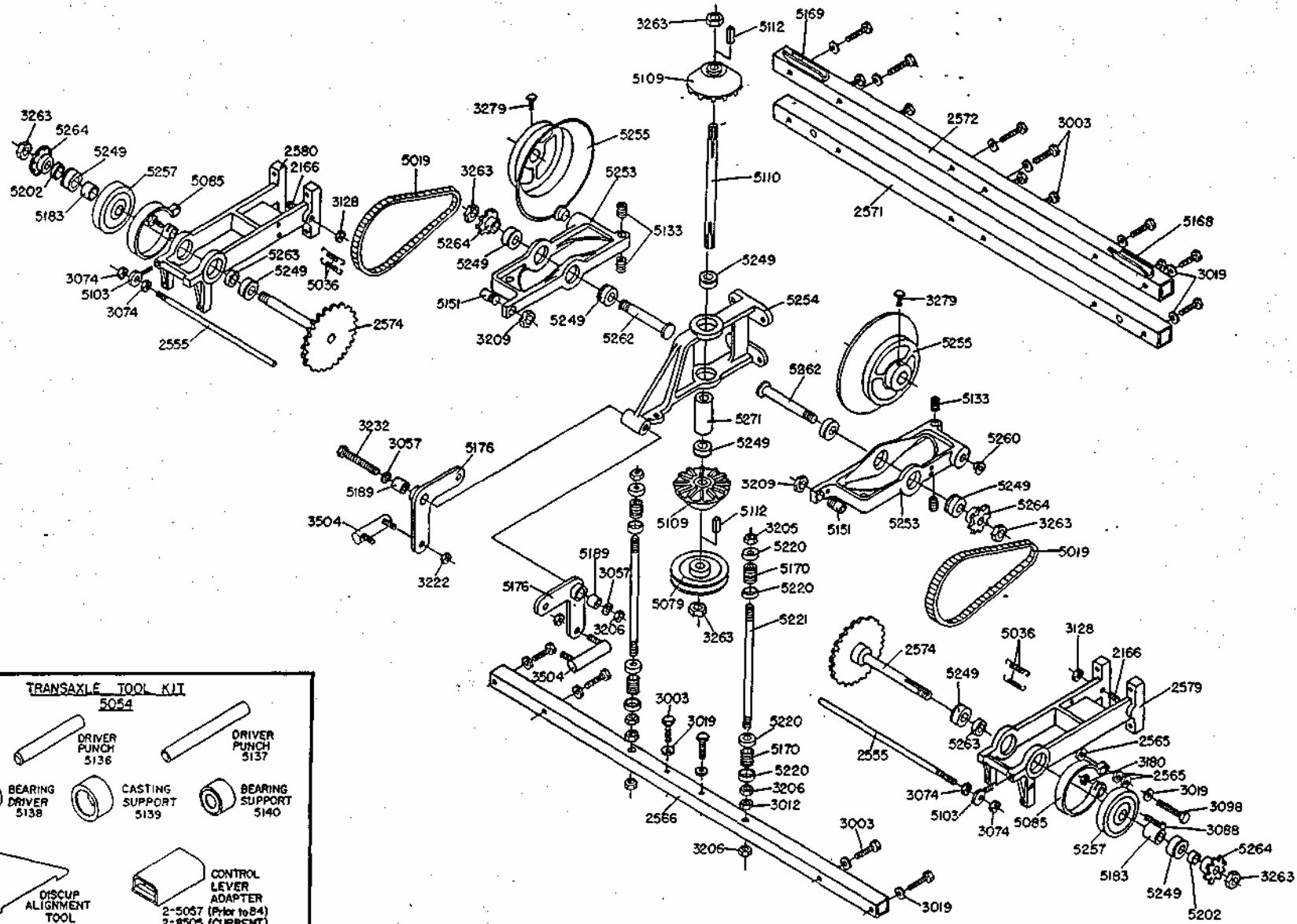
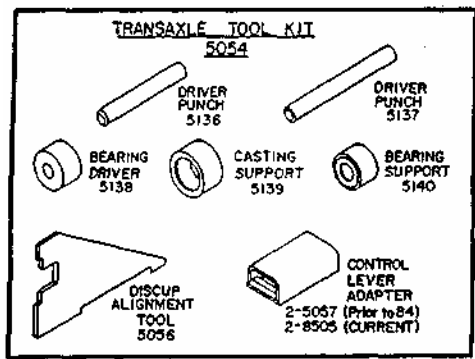

TRANSAXLE ASSEMBLY (MODEL 308 & 311)

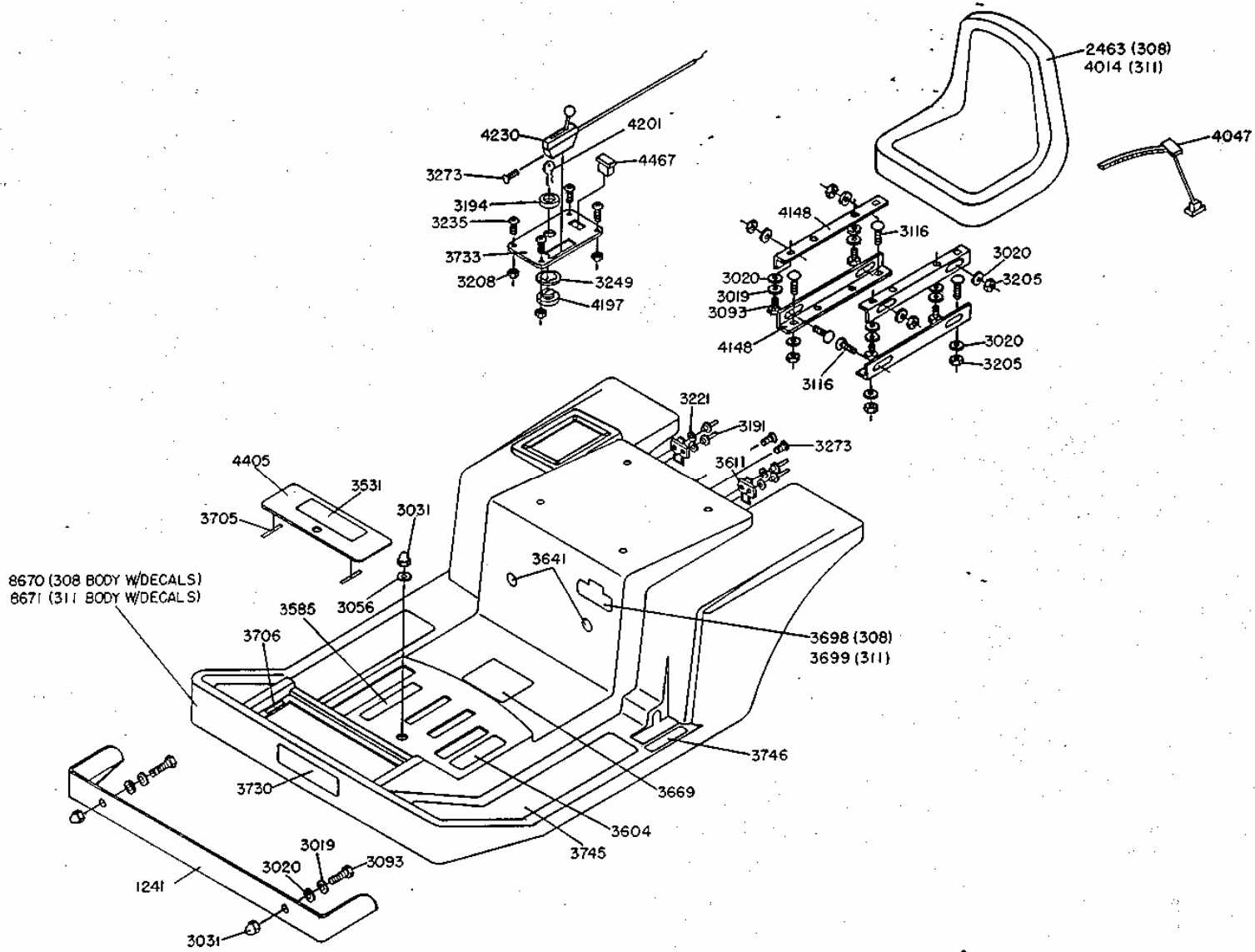

BOBY ASSEMBLY (MODEL ZTR 308 & 311)

MOWER DECK (MODEL ZTR 308 & 311)

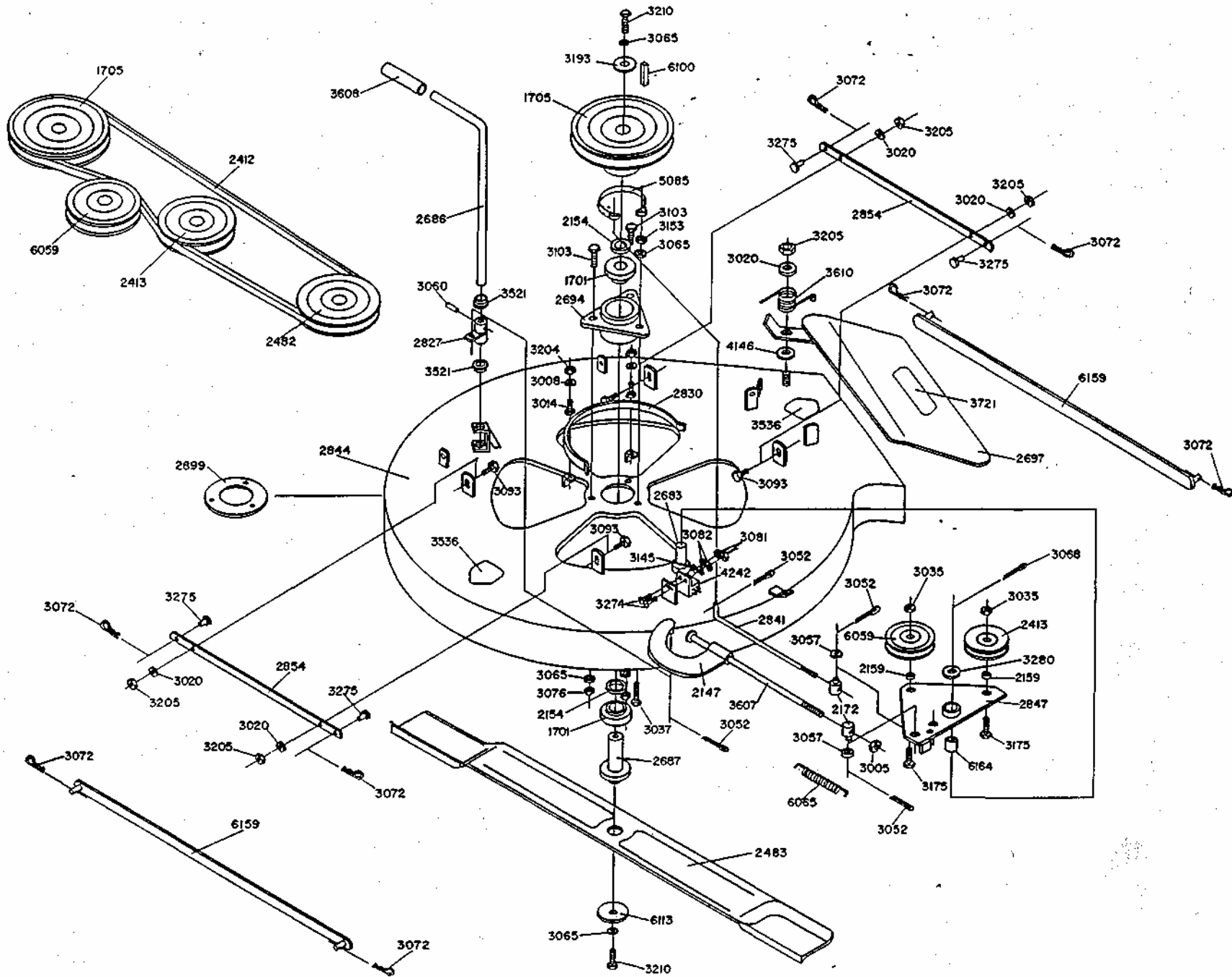

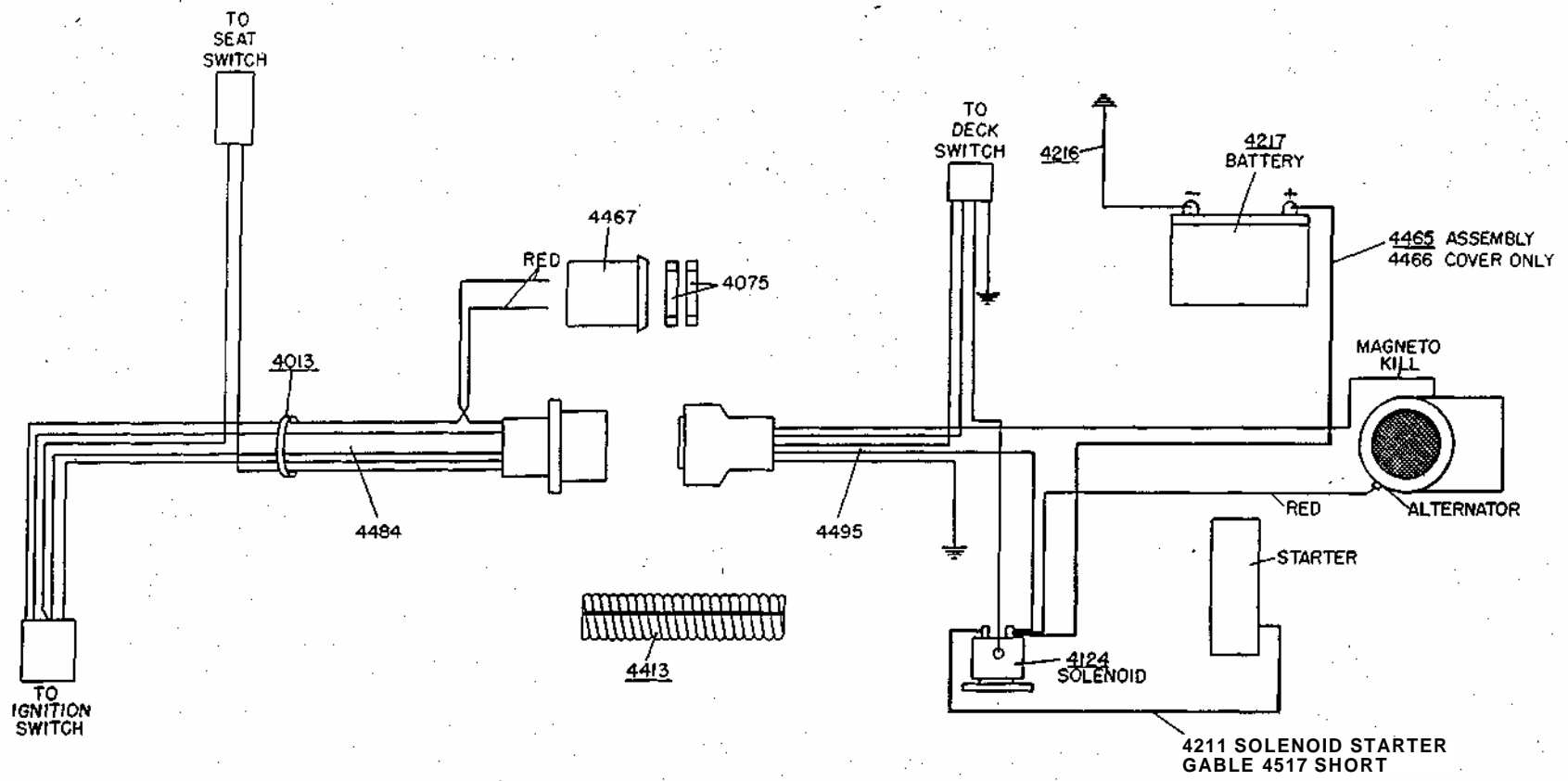

BODY WIRING LOOM - 4484
REAR WIRING LOOM - 4495
WIRING KIT (308-311)-8669
(SEE ASSEMBLY BREAKDOWN)